



ARCONIC

# C6L<sup>®</sup> The Original Vibration-Resistant HuckBolt<sup>®</sup>

Locking Groove Design  
Simple Installation  
Consistent Clamp Force

3/16" - 3/8"



HUCK<sup>®</sup>



---

# The Huck C6L<sup>®</sup>

## The Classic 6-Groove Locking Fastener Built with Staying Power

A result of Huck innovation a half-century ago, the versatile Arconic C6L<sup>®</sup> HuckBolt<sup>®</sup> remains the number one fastening system for applications that require a strong, vibration-resistant seal today.

C6L's exclusive locking groove design ensures a permanent fit that resists loosening. That means it's ideal for applications from general manufacturing to such high-vibration applications as HVAC, trailer and container assembly, rotary and rotating equipment, shopping carts, railroad and transit cars, geodesic structures, and many others.

In addition to offering superior fastening performance, the C6L system reduces labor and installation costs, along with rework and warranty expenses. For example, using the C6L eliminates the need to hire certified welders or specially trained employees, because workers can be instructed to install these foolproof fasteners in a matter of minutes. The C6L is simply stronger, easier to install, and more durable than welding, adhesives, or conventional threaded fastening systems.

**Available Sizes:**

3/16", 1/4", 5/16", 3/8"

**Materials:**

Steel, Aluminum, Stainless Steel

**Headstyles:**

Round, Truss, Flush, 98T

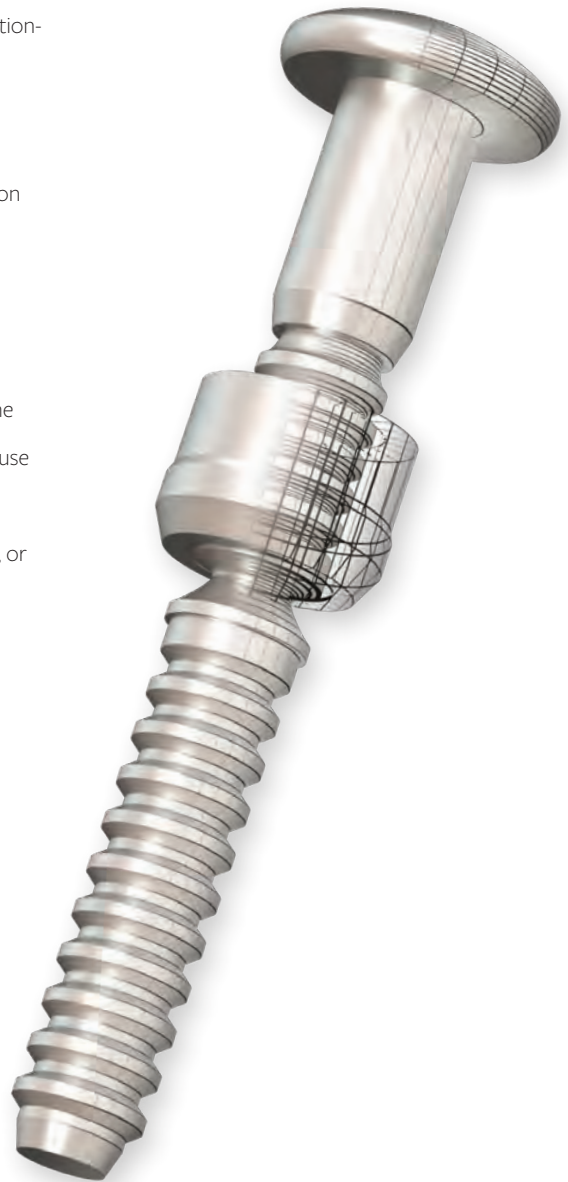

# Installation Sequence

The C6L's unique design virtually eliminates installation errors caused by operator or tool variables. The C6L ensures that once the collar swage is complete, the pintail breaks off and the fastener is tightly installed. No rework required. And you can count on consistent, high-uniform clamp force with every C6L installation, time after time.

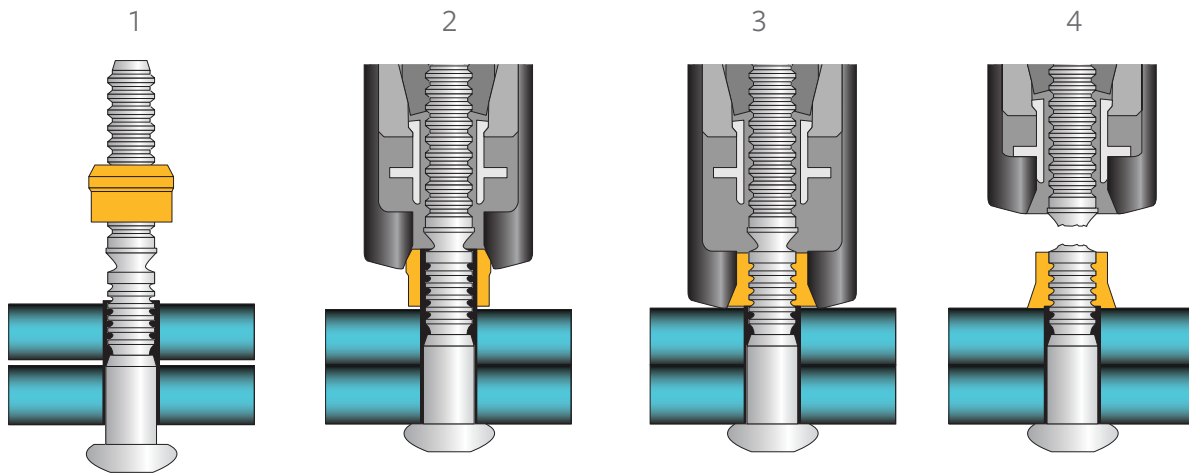

1  
The pin is inserted into the prepared hole and the smooth bore collar is placed on the pin.

2  
The installation tool is applied to the pintail. When the tool is activated, the jaws in the nose assembly pull on the pintail and the nose anvil pushes on the collar to remove any gap.

3  
The nose anvil starts to swage the collar into the lockgrooves on the pin. Continued swaging causes the collar to lengthen and develop clamp.

4  
When swaging of the collar into the lockgrooves is complete, the tool ejects the fastener and releases the puller to complete the sequence.

## Secure, Fast Installation

- Wide bearing collar and head spread load to ensure structural integrity

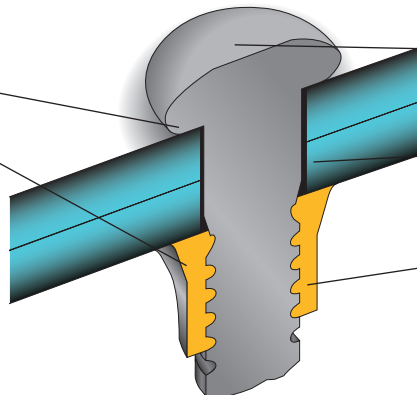

- Corrosion resistant coatings can be painted
- Excellent gap pull-out and high retained clamp
- High fatigue annular lock groove form extends the life of your structure

For Oversized Holes: To optimize clamp, hardened washers such as ASTM F436, DIN 6916 or EN 14399-6 are recommended for use with oversized holes and slots, along with good bolting practice.

# Data and Dimensions

## Head Style Options

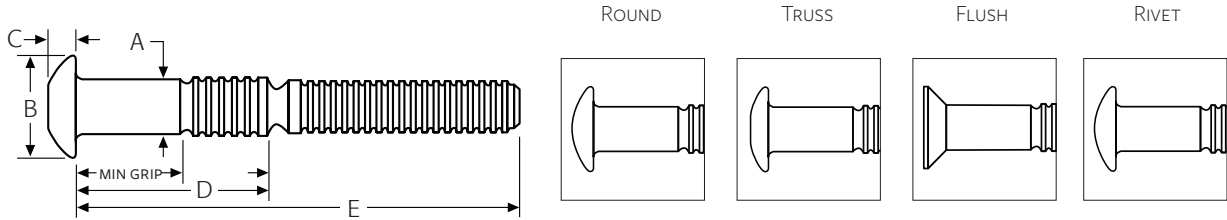

## Fastener Dimensions

DIAMETER	ROUND HEAD			TRUSS HEAD		FLUSH HEAD		RIVET HEAD	
	A	B	C	B	C	B	C	B	C
6 (3/16")	.190-.195	.360-.390	.113-.125	.406-.469	.078-.088			.469	.094
8 (1/4")	.254-.259	.475-.525	.136-.152	.531-.594	.103-.115	.437-.473	.104-.113		
10 (5/16")	.317-.322	.594-.656	.181-.201	.703-.797	.127-.141				
12 (3/8")	.380-.385	.713-.787	.223-.248	.828-.922	.186-.202				

## Collar Style Options

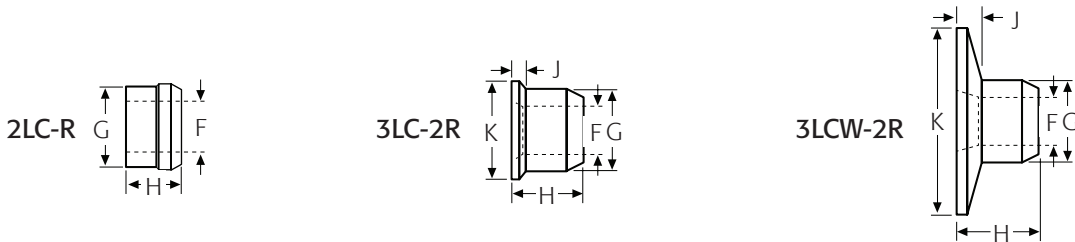

## Collar Dimensions

COLLAR TYPE	PART NUMBER	COLLAR DIAMETER	F DIAMETER	G DIAMETER	H LENGTH	J(1,2) DIMENSION	K DIAMETER
STANDARD	2LC-R, 2LC-F	6 (3/16")	0.187-0.196	0.304-0.311	0.220-0.260		
	LC-I, 2LC-2CU	8 (1/4")	0.256-0.265	0.402-0.409	0.290-0.320		
		10 (5/16")	0.304-0.310	0.485-0.494	0.350-0.380		
		12 (3/8")	0.375-0.385	0.590-0.600	0.430-0.460		
FLANGE	3LC-2R, 3LC-F <sup>1</sup>	6	0.187-0.196	0.304-0.311	0.250-0.280	0.031-0.062	0.359-0.391
	3LC-I, 3LC-2CU <sup>1</sup>	8	0.256-0.267	0.402-0.409	0.349-0.379	0.047-0.078	0.484-0.516
		10	0.304-0.312	0.498-0.507	0.394-0.426	0.062-0.094	0.609-0.641
		12	0.378-0.390	0.599-0.610	0.502-0.532	0.062-0.125	0.719-0.781
WIDE FLANGE	3LCW-2R8 <sup>1</sup>	8	0.253-0.272	0.400-0.409	0.410-0.480	0.105-0.156	0.853-1.022
	3LCW-2R10 <sup>1</sup>	10	0.304-0.312	0.498-0.507	0.474-0.506	0.144-0.196	0.984-1.016

<sup>1</sup> When using 3LC Collars, add "J" dimension to thickness of material being fastened to determine grip number.

<sup>2</sup> When using 8LC collars, subtract "J" dimension from thickness of material being fastened to determine grip number.



### Installed Fastener Values - ibf(KN)

DIAM.	CARBON STEEL (R) PINS			2024 ALUMINUM (C) PINS			6061 ALUMINUM (F) PINS			STAINLESS STEEL (U) PINS		
	2LC-R OR 3LC-2R COLLARS (GRADE 5)			2LC-F OR 3LC-F COLLARS			LC-I OR 3LC-I COLLARS			2LC-2CU OR 3LC-2CU COLLARS		
	SHEAR	CLAMP	TENSILE	SHEAR	CLAMP	TENSILE	SHEAR	CLAMP	TENSILE	SHEAR	CLAMP	TENSILE
6	1725 (2430)	1025 (1200)	1400 (2200)	1050	550	1000	775	350	530	2000	1025	1455
8	3050 (4300)	1805 (2300)	2550 (3800)	1875	950	1800	1375	620	975	3550	1805	2750
10	4725 (6700)	2810 (4200)	3910 (6300)	2925	1500	2850	2125	965	1550	5525	2810	4250
12	6825 (9600)	4020 (5980)	5625 (9300)	4200	2200	4200	3050	1380	2400	7950	4020	6100

### Grip Tables

GRIP	GRIP RANGE	3/16" (6)		1/4" (8)		GRIP	GRIP RANGE	5/16" (10)		3/8" (12)	
		D	E	D	E			D	E	D	E
2	0.063-0.188	0.394	1.404	0.485	1.520						
3	0.125-0.250	0.457	1.466	0.548	1.583						
4	0.188-0.313	0.519	1.529	0.610	1.645	4	0.125-0.375	0.749	1.906	0.809	2.125
5	0.250-0.375	0.582	1.591	0.673	1.708						
6	0.313-0.438	0.644	1.654	0.735	1.770	6	0.250-0.500	0.874	2.031	0.934	2.250
7	0.375-0.500	0.707	1.716	0.798	1.833						
8	0.438-0.563	0.769	1.779	0.860	1.895	8	0.375-0.625	1.000	2.156	1.059	2.375
9	0.500-0.625	0.832	1.841	0.923	1.958						
10	0.563-0.688	0.894	1.904	0.985	2.020	10	0.500-0.750	1.124	2.281	1.184	2.500
11	0.625-0.750	0.957	1.966	1.048	2.083						
12	0.688-0.813	1.019	2.029	1.110	2.145	12	0.625-0.875	1.249	2.406	1.309	2.625
13	0.750-0.875	1.082	2.091	1.173	2.208						
14	0.813-0.938	1.144	2.154	1.235	2.270	14	0.750-1.000	1.374	2.531	1.434	2.750
15	0.875-1.000	1.207	2.216	1.298	2.333						
16	0.938-1.063	1.269	2.279	1.360	2.395	16	0.875-1.125	1.500	2.656	1.559	2.875
17	1.000-1.125	1.332	2.341	1.423	2.458						
18	1.063-1.188	1.394	2.404	1.458	2.520	18	1.000-1.250	1.624	2.781	1.684	3.000
19	1.125-1.250	1.457	2.466	1.548	2.583						
20	1.188-1.313	1.519	2.529	1.610	2.645	20	1.125-1.375	1.749	2.906	1.809	3.125
21	1.250-1.375	1.582	2.591	1.673	2.708						
22	1.313-1.438	1.644	2.654	1.735	2.770	22	1.250-1.500	1.874	3.031	1.934	3.250
23	1.375-1.500	1.707	2.716	1.798	2.833						
24	1.438-1.563			1.866	2.895	24	1.375-1.625	2.000	3.156	2.059	3.375
25	1.500-1.625			1.923	2.958						
26	1.563-1.688			1.985	3.020	26	1.500-1.750	2.124	3.281	2.184	3.500
27	1.625-1.750			2.048	3.083						
28	1.688-1.813			2.110	3.145	28	1.625-1.875	2.249	3.406	2.309	3.625
29	1.750-1.875			2.173	3.208						
30	1.813-1.938			2.235	3.270	30	1.750-2.000	2.374	3.531	2.434	3.750
31	1.875-2.000			2.298	3.333						
32	1.938-2.063			2.368	3.395	32	1.875-2.125	2.500	3.656	2.559	3.875
37				2.637	3.708						

# C6L Inspection Data and Installation Tooling

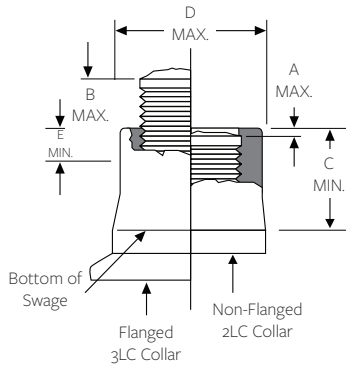

Inspection Data							
NOMINAL SIZE	A MAX	B MAX	C MIN	D MAX	E MIN	HOLE SIZE	
						2LC COLLAR	3LC COLLAR
STRAIGHT BORE ANVIL TOOLING							
6 (3/16")	.078	.125	.172	.276	–	.218	.234
8 (1/4")	.078	.156	.250	.364	–	.281	.312
10 (5/16")	.140	.219	.281	.454	–	.359	.390
12 (3/8")	.125	.281	.344	.552	–	.421	.468
TAPERED BORE ANVIL TOOLING (99-3003 AND 99-3006)							
6 (3/16")	.040	.125	.180	.276	.115	.218	.234
8 (1/4")	.030	.156	.230	.364	.085	.281	.312

Should “A” or “B” dimensions exceed the given values, the fastener is out-of-grip. A “C” dimension less than the given value indicates an incomplete swage. A “D” dimension greater than the given values indicates an incorrect or worn anvil on the installation tool. “E” is the minimum length from the top of the collar to measure “D” diameter for tapered bore anvils.

Installation Tools		PNEUDRAULIC TOOLS				HYDRAULIC TOOLS	
TOOL MODEL	SIZE	244X	254	256	2025 <sup>1,2</sup>	2480	2581
Nose ASSEMBLY	3/16"	99-2555-HD	99-2558	99-2558	99-3003 <sup>1,2</sup>	99-2555-HD 99-3003 <sup>1</sup>	99-2558
	1/4"	99-3417	99-2564	99-2564	99-3006 <sup>1,2</sup>	99-3006 <sup>1</sup> 99-3417	99-2564
	5/16"		99-99-245	99-99-245			99-99-245
	3/8"		99-100-245	99-100-245			99-100-245



Tooling Weight and Dimensions					
MODEL	TYPE	WEIGHT	LENGTH	HEIGHT	WIDTH
244X	PNEUDRAULIC	5.75 LBS	6.9"	13.1"	4.7"
254	PNEUDRAULIC	8.7 LBS	8.1"	14.9"	5.0"
256	PNEUDRAULIC	11.1 LBS	7.8"	14.9"	6.1"
2025 <sup>1,2</sup>	PNEUDRAULIC	5.75 LBS	8.4"	12.5"	4.4"
2480	HYDRAULIC	2.2 LBS	8.6"	6.5"	1.9"
2581	HYDRAULIC	5.5 LBS	8.4"	7.1"	2.1"

<sup>1</sup> Note: When using tapered bore anvils, use visual inspection data for tapered bore anvil tooling. <sup>2</sup> Model 2025 is not recommended for high volume installation of stainless steel fasteners.

# Ordering Information

Follow the form below to construct a part number for ordering C6L pins and their respective collars. Refer to the Grip Data chart for grip numbers.

## Pins (Grade 2 Steel, Aluminum, Stainless Steel)

C6L — (MATERIAL) (DIAMETER) — (GRIP NUMBER) (FINISH)

Example: C6LT-R8-4G is a C6L HuckBolt Pin, Truss Head, Carbon Steel, 1/4" Diameter, Grip 4, Zinc Finish

HEAD STYLE	PREFIX	MATERIAL	CODE	DIAMETER	CODE	GRIP	FINISH	SUFFIX
ROUND	C6LB	GRADE 2 CARBON STEEL	R	3/16"	6	REFER TO GRIP TABLE ON PAGE 5	ZINC	G
TRUSS	C6LT	2024 ALUMINUM ALLOY	C	1/4"	8			
FLUSH	C6L90	6061 ALUMINUM ALLOY	F	5/16"	10			
RIVET	C98LT	STAINLESS STEEL	U	3/8"	12			

## Collars (Grade 2 Steel, Aluminum, Stainless Steel)

(TYPE) – (MATERIAL) (DIAMETER) (FINISH)

Example: 2LC-R8G is a Standard C6L HuckBolt Collar, Carbon Steel, 1/4" Diameter, Zinc Finish

HEAD STYLE	PREFIX	MATERIAL	CODE	DIAMETER	CODE	FINISH	SUFFIX
STANDARD	2LC	CARBON STEEL	2R/R	3/16"	6	ZINC	G
FLANGE	3LC	6061 ALUM ALLOY HEAT TREATED	I	1/4"	8		
WIDE FLANGE	3LCW	6061 ALUM ALLOY	F	5/16"	10		
		STAINLESS STEEL	2CU	3/8"	12		

\*Optional tablock on collars

## Pins (Grade 5)

C12oL (HEAD STYLE) — (MATERIAL) (DIAMETER) — (GRIP NUMBER) (FINISH)

Example: C12oLT-R8-4G is a C12oL HuckBolt Pin, Truss Head, Carbon Steel, 1/4" Diameter, Grip 4, Zinc Finish

HEAD STYLE	PREFIX	MATERIAL	CODE	DIAMETER	CODE	GRIP	FINISH	SUFFIX
ROUND	C120B	GRADE 5 CARBON STEEL	R	3/16"	6	REFER TO GRIP TABLE ON PAGE 5	ZINC	G
TRUSS	C120T			1/4"	8			
FLUSH	120L90			5/16"	10			
				3/8"	12			

## Collars (Grade 5)

(TYPE) – (MATERIAL) (DIAMETER) (FINISH)

Example: 2LC12o-R8G is a Standard C12oL HuckBolt Collar, Carbon Steel, 1/4" Diameter, Zinc Finish

GRADE 5	PREFIX	MATERIAL	CODE	DIAMETER	CODE	FINISH	SUFFIX
STANDARD	2LC120	CARBON STEEL	2R/R	3/16"	6	ZINC	G
FLANGE	3LC120			1/4"	8		
				5/16"	10		
				3/8"	12		

# Arconic Fastening Systems



Arconic Inc. (NYSE: ARNC) creates breakthrough products that shape industries, providing solutions to complex engineering challenges to transform the way we fly, drive, build, and power. Combining ingenuity and advanced manufacturing, we deliver products that meet the challenges and demands faced by our customers.

Arconic Fastening Systems, formerly Alcoa Fastening Systems & Rings, is a global leader in fastening technology. Offering the greatest breadth and depth of fastening system solutions in the industry, Arconic continues to reflect the same commitment to product quality and support that customers have come to expect. To serve its growing market, Arconic Fastening Systems maintains corporate offices worldwide. In addition, Arconic distributors are located in many key industrial centers throughout the world, providing a ready supply of fasteners, installation tools, tool parts, and application assistance.

## Americas

Waco Operations  
8001 Imperial Drive  
Waco, TX 76712, USA  
P.O. Box 8117  
Waco, TX 76714-8117, USA  
Tel: +1 800 388 4825  
Fax: +1 800 798 4825

Kingston Operations  
1 Corporate Drive  
Kingston, NY 12401, USA  
Tel: +1 800 278 4825  
Fax: +1 845 334 7333

Tracy Operations  
1925 North MacArthur Drive  
Tracy, CA 95376, USA  
Tel: +1 800 826 2884  
Fax: +1 800 573 2645

Carmel Operations  
14300 Clay Terrace Blvd.  
Suite 250  
Carmel, IN 46032, USA  
Tel: +1 800 826 2884  
Fax: +1 800 573 2645

Tacubaya Operations  
Avenida Parque Lira  
79-402 Tacubaya  
Mexico C P 11850  
Tel: +52 55 5515 1776  
Fax: +52 55 5277 7564

São Paulo Operations  
Av. Nações Unidas, 12.901  
Torre Oeste, 3º andar  
São Paulo – SP – Brasil  
04578-000  
Tel: +55 0800 015 9888  
Fax: +55 11 5509 0200

## International Locations

Kolkata Operations  
Unit no. 28, Chowringhee Court  
55/1, Chowringhee Road  
Kolkata – 700071  
India  
Tel: +91 33 4069 9170/80  
Fax: +91 33 4069 9184

Tokyo Operations  
Arconic Japan Ltd.  
#1013 NBF Hibiya Bldg, Uchisaiwai-cho,  
Chiyoda-ku  
Tokyo 100-1011  
Japan  
Tel: +81 3 3539 6577  
Fax: +81 3 3539 6585

Melbourne Operations  
1508 Centre Road  
Clayton, Victoria, 3168  
Australia  
Tel: +61 3 8545 3333  
Fax: +61 3 8545 3390

Suzhou Fasteners Operations  
58 Yinsheng Road, Shengpu  
Suzhou Industrial Park  
Suzhou Jiangsu 215126  
China  
Tel: +86 0512 62863800-8888  
Fax: +86 0512 62863810

Telford Operations  
Unit C, Stafford Park 7  
Telford, Shropshire TF3, 3BQ  
United Kingdom  
Tel: +44 1952 2900 11  
Fax: +44 1952 2904 59

St. Cosme Operations  
9 rue de Cressonnieres  
72110 Saint Cosme en Varais  
France  
Tel: +33 0 2 43 31 41 00  
Fax: +33 0 2 43 31 41 41

Kelkheim Operations  
Industriestr. 6  
65779 Kelkheim  
Germany  
Tel: +49 (0) 6195 8050  
Fax: +49 (0) 6195 2001



[afshuck.net/us](http://afshuck.net/us)  
[YouTube.com/AFSIndustrial](https://www.youtube.com/AFSIndustrial)

The information contained in this publication is only for general guidance, and is not intended to create any warranty, express, implied, or statutory; all warranties are contained only in AFS's written quotations, acknowledgments, and/or purchase orders. It is recommended that the user secure specific, up-to-date data and information regarding each application and/or use of such products.

