



ARCONIC

HuckLok[®] Blind Rivets

Double-Locking, Wide-Grip Fasteners for
Superior Strength in a Broad Variety
of Applications





HuckLok®

A Structural Bulbing Fastener Ideal for Joining a Broad Range of Materials with Variation of Grip Thicknesses.

Featuring a wide grip range and unique double-locking action, the HuckLok® structural blind rivet combines high shear strength and high pull-up force. Its double-locking action consistently secures the assembly from both sides, resulting in maximum hold and joint integrity. Its large, blind-side footprint prevents pull-through, even when joining a wide range of materials with varying grip thicknesses.

In addition, HuckLok's® positive mechanical core pin retention design ensures structural integrity and long joint life. Its breakaway ring design lets the shear ring settle into the appropriate catch groove, keeping pressure on the blindside and securing a consistent clamp throughout the entire wide grip range.

Designed to add efficiency to a wide range of joining applications, HuckLok blind rivets are easy to install in seconds. A quick visual review is all that is necessary to confirm the accuracy of the installation, since the installed HuckLok's core pin being flush on the head of the sleeve is proof of the success of the process.

Available Sizes:

3/16", 1/4"

Materials:

Steel

Headstyles:

Protruding, Truss, 100° Oval Flush

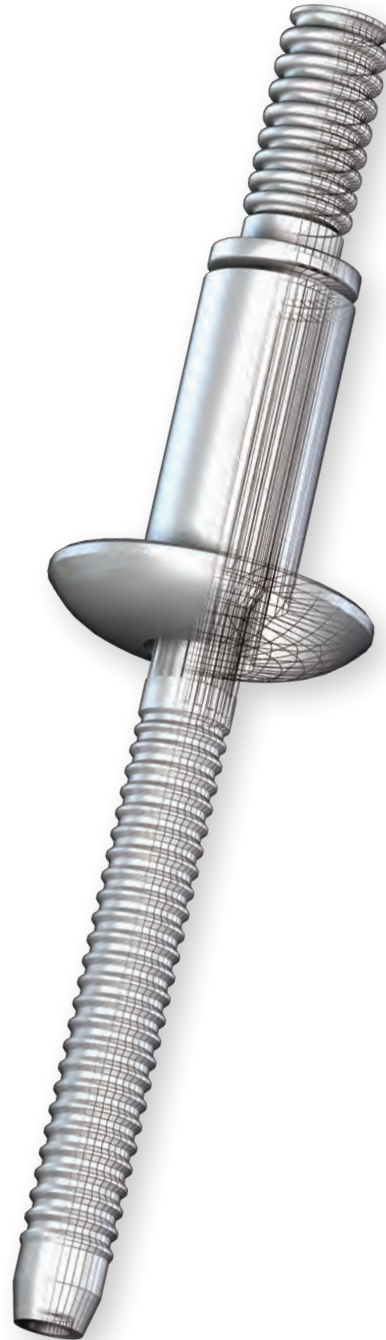

Installation Sequence

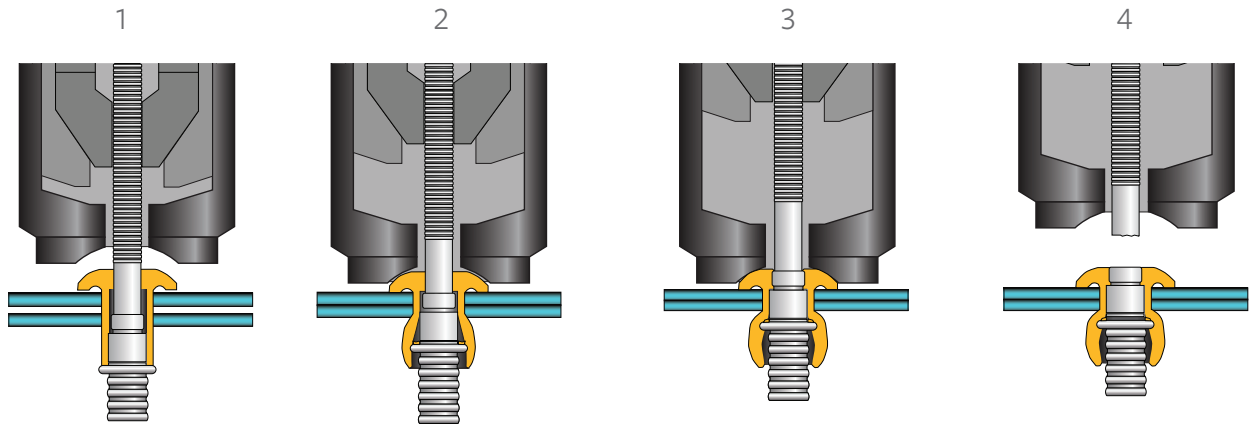

1
Insert the fastener into the hole and slip the installation tool over the pintail.

2
Press the trigger to initiate pulling action. As the tool pulls on the pintail, the shear ring feature on the pin pulls inside the sleeve fully expanding the diameter and drawing the work pieces together.

3
Continued pulling on the pintail expands the sleeve to maximum allowable diameter. As the shear ring reaches the backside of the work piece it breaks and catches on the tapered annular grooves, keeping high pressure on the blind side of the work pieces as the pin continues to draw down inside the sleeve.

4
A solid circle lock between the pin and sleeve is formed just prior to the pin breaking flush with the sleeve head, completing the installation.

Secure, Fast Installation

Breaking flush throughout its grip range, the HuckLok blind rivet lets the worker verify installation accuracy at a glance and eliminates costly cosmetic finishing

Undercut fillet allows seating in burred holes

Solid pin provides exceptionally high strength in the shear plane

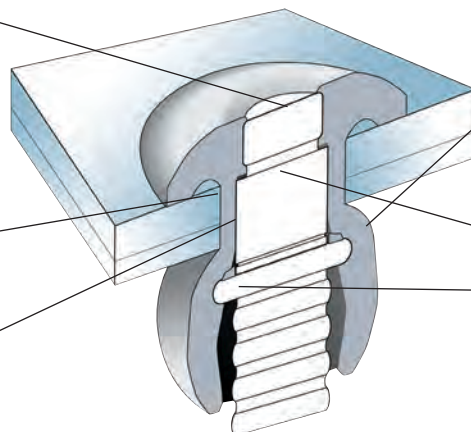

The HuckLok's wide footprint provides a broad blind-side bearing surface that resists pull-through

Lock groove on pin engages shoulder on rivet head, while the support ring "double locks" the pin within the bulb

Data and Dimensions

Head Style Options

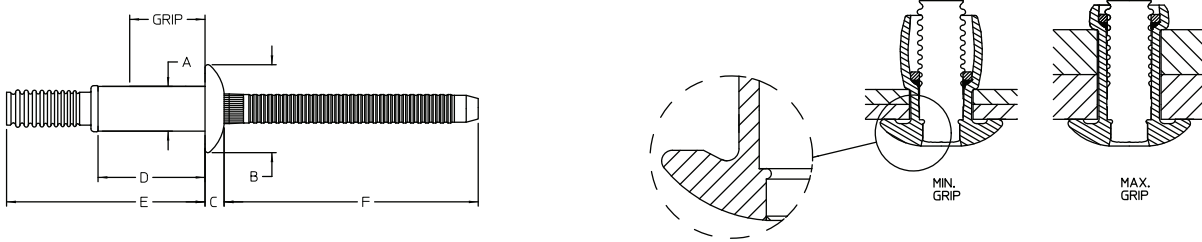

Fastener Dimensions

DIAMETER	PART NUMBER		GRIP RANGE (IN)	GRIP RANGE (MM)	HOLE SIZE	ANOM	B Max		C Max	D Max	E Max	F Min
	PROTRUDING	TRUSS					PROTRUDING	TRUSS				
6 (3/16")	HKLP-R6-5	-	.062 - .312	1.6 - 7.9	.191 - .201	0.187	0.395	-	0.101	0.458	0.8555	0.988
	HKLP-R6-7	-	.187 - .437	4.7 - 11.1	.191 - .201	0.187	0.395	-	0.101	0.583	0.9805	0.978
8 (1/4")	HKLP-R8-6	HKLT-R8-6	.100 - .375	2.5 - 9.5	.261 - .272	0.253	0.530	0.592	0.122	0.560	1.019	1.082
	HKLP-R8-6X	HKLT-R8-6X	.080 - .375	2.0 - 9.5	.261 - .272	0.253	0.530	0.592	0.122	0.560	1.019	1.082
	HKLP-R8-X6	-	.180 - .375	4.6 - 9.5	.261 - .272	0.253	0.530	-	0.122	0.560	1.019	1.102
	HKLP-R8-7	HKLT-R8-7	.187 - .437	4.7 - 11.1	.261 - .272	0.253	0.530	0.592	0.122	0.622	1.081	1.065
	HKLP-R8-10	HKLT-R8-10	.375 - .625	9.5 - 15.9	.261 - .272	0.253	0.530	0.592	0.122	0.810	1.269	1.065
	HKLP-R8-12	HKLT-R8-12	.500 - .750	12.7 - 19.1	.261 - .272	0.253	0.530	0.592	0.122	0.934	1.393	1.066
	HKLP-R8-14	HKLT-R8-14	.625 - .875	15.9 - 22.2	.261 - .272	0.253	0.530	0.592	0.122	1.060	1.519	1.065
	HKLP-R8-18	HKLT-R8-18	.875 - 1.125	22.2 - 28.6	.261 - .272	0.253	0.530	0.592	0.122	1.310	1.769	1.065
HKLP-R8-20	HKLT-R8-20	1.000 - 1.250	25.4 - 31.8	.261 - .272	0.253	0.530	0.592	0.122	1.435	1.894	1.065	

Installed Values - Ibf (Minimum)

DIAM.	PART NUMBER		SHEAR		TENSILE		RETENTION	
			MIN	Typ	MIN	Typ	MIN	Typ
6 (3/16")	HKLP	ALL GRIPS	1900	2500	1000	1300	150	450
8 (1/4")	HKLP/HKLT	ALL GRIPS	3500	3800	1900	2200	300	650



Lock groove on pin engages shoulder on rivet head, while the support ring "double locks" the pin within the bulb.

Materials and Finishes

MATERIAL	SLEEVE	PIN	SLEEVE FINISH	PIN FINISH
STEEL	LOW CARBON STEEL	MEDIUM CARBON STEEL	ZINC PLATE WITH CLEAR GOLD DYE OPTIONAL	ZINC PLATE WITH CLEAR GOLD DYE OPTIONAL

Ordering Information

HKL(HEAD STYLE) - (MATERIAL) (DIAMETER) — (GRIP NUMBER)

Example: HKLP-R6-5 is a Protruding Head HuckLok, Steel, 3/16" Diameter, 5/16" Grip

HEAD STYLE	PREFIX
PROTRUDING HEAD	P
TRUSS HEAD	T

MATERIAL	CODE
STEEL	R
-	-

DIAMETER	CODE
3/16"	6
1/4"	8



Installation Tooling

Tooling Weight and Dimensions

MODEL	TYPE	WEIGHT	LENGTH	HEIGHT	WIDTH
254	PNEUDRAULIC	8.7 LBS	8.1"	14.9"	5.0"
256	PNEUDRAULIC	11.1 LBS	7.9"	14.9"	6.3"
2015	PNEUDRAULIC	4.9 LBS	10.6"	12"	3.5"
2022	PNEUDRAULIC	5.4 LBS	8.6"	12.6"	4.4"
2024*	PNEUDRAULIC	5.75 LBS	8.9"	12.6"	4.4"
2025	PNEUDRAULIC	5.8 LBS	8.5"	12.7"	4.4"
2480	HYDRAULIC	2.2 LBS	8.2"	6.6"	1.9"
2581	HYDRAULIC	5.5 LBS	8.4"	7.1"	2.1"

* Recommended

** Not recommended for high volume production

Installation Tools

		PNEUDRAULIC TOOLS							
TOOL MODEL	SIZE	254	256	2015	2022	2024*	2025	2480	2581
NOSE ASSEMBLY	3/16"	99-3327	99-3327	INCLUDED	99-3303	99-3303	99-3303	99-3303	99-3327
	3/16" & 1/4"	-	-	-	99-3487	99-3487**	99-3487**	-	-
	1/4"	99-3328	99-3328	INCLUDED	99-3305	99-3305	99-3305	99-3305	99-3328

* Recommended

** Not recommended for high volume production



Huck Pneudraulic Tooling



245

The 245 is sized for high-speed production applications, up to 20 fastener installations per minute. This tool provides optimum stroke for one-cycle installations, and features an eccentric pull piston for limited clearance applications. Chrome-plated piston rods in the 245 extend the life of the seals.



246

The 246 production tool features optimum stroke for one-cycle installation and has an eccentric pull piston for limited clearance applications. The Model 246 has chrome plated piston rods to extend the life of the seals.



255

The Model 255 tool is sized for high-speed production applications, up to 20 fastener installations per minute. This tool can install fasteners up to 3/8" steel C6L HuckBolts, with optimum stroke for one-cycle installations. A versatile tool, the Model 255 features a concentric (inline) pull piston and new front gland design, allowing for easy piston removal. Plated piston rods in the Model 255 extend the life of the seals. The 255 is factory-tested for 2000 cycles, ensuring a high level of reliability. Despite its outstanding production capacity, the Model 255 weighs only 8.80 pounds.



256

Designed for quick installation of fasteners, the 256 tool features optimum stroke for one-cycle fastener installation, and minimal moving parts. Comes with standard inline and offset nose assemblies, ranging from 4mm to 10mm.



2015

The Model 2015 is a lightweight, high-speed tool that is well-suited for both production and maintenance/repair applications where 1/4", and smaller, diameter blind fasteners are used. The 2015 features an in-line piston for one-stroke installations of up to 35 cycles per minute. Operator fatigue is minimized through an ergonomically designed handle and the tool's light weight (4.80 pounds). Anvil inserts for nail-type rivets can be easily changed out on the Model 2015 to accommodate various sizes. The tool's nose diameter of .78" makes it ideal for close clearance applications.



2022

The Model 2022 is a lightweight, high-speed tool that is well-suited for both production and maintenance/repair applications where 1/4" and smaller diameter (standard and extended grip) blind fasteners are used. The 2022 features an in-line long stroke piston for production rates of up to 30 installations per minute. The 2022's ergonomically designed handle and light weight (5.4 pounds) combine to minimize operator fatigue.

Huck Pneudraulic Tooling



2024

Designed for production volume fastening, the 2024 offers a number of outstanding features, including an ergonomically designed handle, plated piston rods and an efficient in-line piston. An extended piston version (2024L) is available and an optional vacuum assist pintail collection system (2024V) can be added.



2025

With an ergonomically designed handle, plated piston rods and an efficient in-line piston, the 2025 tool is ideal for high-volume production fastening. An extended piston version (2025L) is available and an optional vacuum assist pintail collection system (2025V) can also be added.



Huck AK-175

Built for maintenance and repair applications in the shop or in the field, the Huck AK-175 riveter is compact and lightweight at only 26 oz. Despite its light weight, it develops 3,500 pounds of pulling force. Highly versatile, the AK-175 features a unique jaw system allowing setting of rivets from 1/8" through 1/4" using changeable nosepieces.

Huck Hydraulic Tooling



2480

The Model 2480 is a very lightweight tool which provides for the high-speed installation of a wide range of HuckBolt and Huck blind bolt fasteners. The tool has only one moving part, resulting in outstanding reliability and minimal maintenance. The tight centerline-to-edge measurement of the Model 2480 and its light weight (2.21 pounds) allow for its use in limited clearance areas.



2580

The Model 2580 is a lightweight tool (only 6.58 pounds) designed for use in a wide range of high-speed production applications. With only one moving part, the tool provides for increased reliability and requires minimal maintenance. An offset piston design allows the Model 2580 to easily fit in limited clearance applications.

NOTE: For additional tool details, refer to the specific fastener brochure or visit AFShuck.net.

Arconic Fastening Systems



Arconic Inc. (NYSE: ARNC) creates breakthrough products that shape industries, providing solutions to complex engineering challenges to transform the way we fly, drive, build, and power. Combining ingenuity and advanced manufacturing, we deliver products that meet the challenges and demands faced by our customers.

Arconic Fastening Systems, formerly Alcoa Fastening Systems & Rings, is a global leader in fastening technology. Offering the greatest breadth and depth of fastening system solutions in the industry, Arconic continues to reflect the same commitment to product quality and support that customers have come to expect. To serve its growing market, Arconic Fastening Systems maintains corporate offices worldwide. In addition, Arconic distributors are located in many key industrial centers throughout the world, providing a ready supply of fasteners, installation tools, tool parts, and application assistance.

Americas

Waco Operations
8001 Imperial Drive
Waco, TX 76712, USA
P.O. Box 8117
Waco, TX 76714-8117, USA
Tel: +1 800 388 4825
Fax: +1 800 798 4825

Kingston Operations
1 Corporate Drive
Kingston, NY 12401, USA
Tel: +1 800 278 4825
Fax: +1 845 334 7333

Tracy Operations
1925 North MacArthur Drive
Tracy, CA 95376, USA
Tel: +1 800 826 2884
Fax: +1 800 573 2645

Carmel Operations
14300 Clay Terrace Blvd.
Suite 250
Carmel, IN 46032, USA
Tel: +1 800 826 2884
Fax: +1 800 573 2645

Tacubaya Operations
Avenida Parque Lira
79-402 Tacubaya
Mexico C P 11850
Tel: +52 55 5515 1776
Fax: +52 55 5277 7564

São Paulo Operations
Av. Nações Unidas, 12.901
Torre Oeste, 3º andar
São Paulo – SP – Brasil
04578-000
Tel: +55 0800 015 9888
Fax: +55 11 5509 0200

International Locations

Kolkata Operations
Unit no. 28, Chowringhee Court
55/1, Chowringhee Road
Kolkata – 700071
India
Tel: +91 33 4069 9170/80
Fax: +91 33 4069 9184

Tokyo Operations
Arconic Japan Ltd.
#1013 NBF Hibiya Bldg, Uchisaiwai-cho,
Chiyoda-ku
Tokyo 100-1011
Japan
Tel: +81 3 3539 6577
Fax: +81 3 3539 6585

Melbourne Operations
1508 Centre Road
Clayton, Victoria, 3168
Australia
Tel: +61 3 8545 3333
Fax: +61 3 8545 3390

Suzhou Fasteners Operations
58 Yinsheng Road, Shengpu
Suzhou Industrial Park
Suzhou Jiangsu 215126
China
Tel: +86 0512 62863800-8888
Fax: +86 0512 62863810

Telford Operations
Unit C, Stafford Park 7
Telford, Shropshire TF3, 3BQ
United Kingdom
Tel: +44 1952 2900 11
Fax: +44 1952 2904 59

St. Cosme Operations
9 rue de Cressonnieres
72110 Saint Cosme en Varais
France
Tel: +33 0 2 43 31 41 00
Fax: +33 0 2 43 31 41 41

Kelkheim Operations
Industriestr. 6
65779 Kelkheim
Germany
Tel: +49 (0) 6195 8050
Fax: +49 (0) 6195 2001



afshuck.net/net
[YouTube.com/AFSIndustrial](https://www.youtube.com/AFSIndustrial)

The information contained in this publication is only for general guidance, and is not intended to create any warranty, express, implied, or statutory; all warranties are contained only in AFS's written quotations, acknowledgments, and/or purchase orders. It is recommended that the user secure specific, up-to-date data and information regarding each application and/or use of such products.



ARCONIC